

Test: Primary 5 Science (Term 1) - Nan Hua

Points: 60 points

Name: _____

Score: _____

Date: _____

Signature: _____

Select multiple choice answers with a cross or tick:

Only select one answer

Can select multiple answers

Question 1 of 63

Primary 5 Science (Term 1) 2 pts

Section A (28 x 2 marks = 56 Marks)

Which one of the following statements correctly describe cells?

-
- A)** A cell is a living thing and can reproduce
- B)** The cells of an elephant are much larger than a rat
- C)** All living things are made up of more than one cell
- D)** All living things and non-living things are made up of cells.

The diagram below shows a cell.

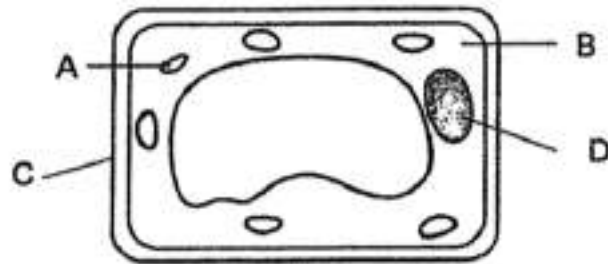

Which of the parts, A, B, C and D, are usually present in plant cells but not in animal cells?

-
- A) A and B
 - B) A and C
 - C) B and D
 - D) C and D

The diagram below shows cell X taken from a living thing.

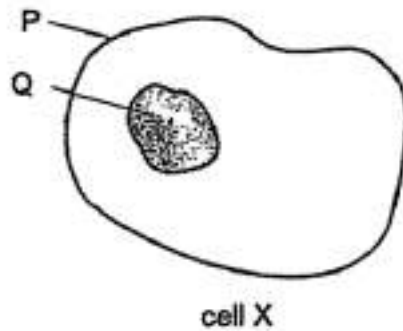

Which of the following correctly describes the functions of parts P and Q?

	P	Q
(1)	Makes food	Controls all the activities in the cell
(2)	Controls all the activities in the cell	Makes food
(3)	Controls the movement of substances in and out of the cell	Controls all the activities in the cell
(4)	Controls all the activities in the cell	Controls the movement of substances in and out of the cell

- A) 1
 B) 2
 C) 3
 D) 4

The diagram below shows the reproductive parts of a flower.

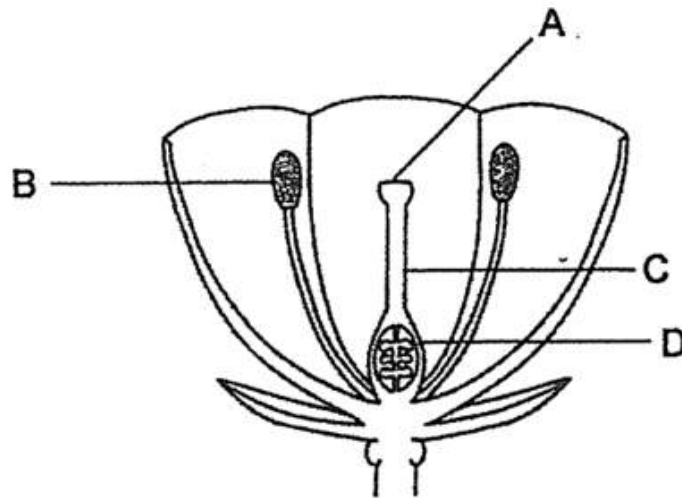

At which part is the egg cell produced?

-
- A) A
 - B) B
 - C) C
 - D) D

The arrows in the diagrams below show the transfer of pollen grains.



flower W

flower X



flower Y

flower Z

Based on the diagrams above, which of the following flowers is likely to be pollinated?

- A) W
- B) X
- C) Y
- D) Z

The diagram below shows a flower that has not been pollinated. The flower is able to develop into a fruit even though two parts of the flower are removed.

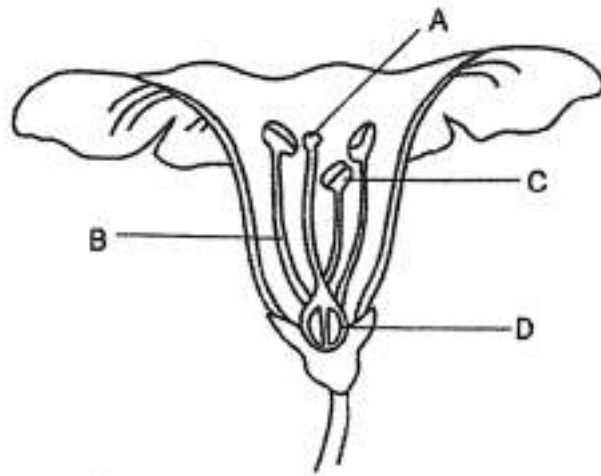

Which two parts of the flower are removed and still allow the flower to develop into a fruit?

-
- A) A and B
 - B) A and C
 - C) B and C
 - D) C and D

The diagram below shows a fruit.

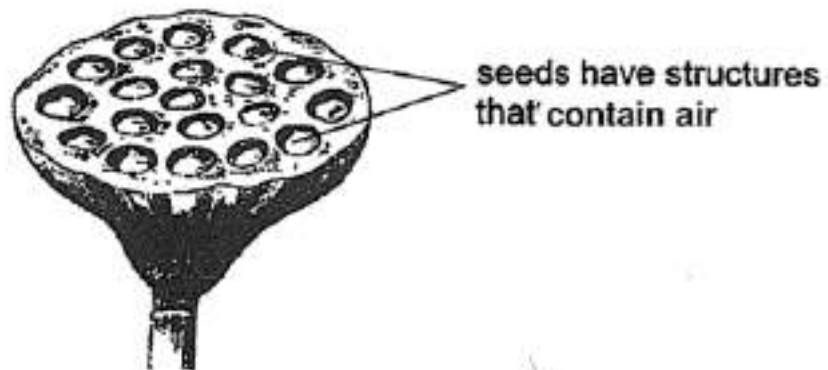

How are the seeds of the fruit likely to be dispersed?

-
- A) By wind
 - B) By water
 - C) By animal
 - D) By splitting

The characteristics of three organisms are shown below.

Characteristics	Organisms		
	R	S	T
Makes its own food	Yes	No	Yes
Produces pollen grains	No	No	Yes
Produces spores	Yes	Yes	No

What could organisms R, S and T be?

	R	S	T
(1)	fungi	non-flowering plant	flowering plant
(2)	non-flowering plant	fungi	flowering plant
(3)	non-flowering plant	flowering plant	fungi
(4)	flowering plant	fungi	non-flowering plant

- A) 1
- B) 2
- C) 3
- D) 4

The freezing point and boiling point of substances X and Y are shown below.

Substance	X	Y
Freezing point (°C)	43	6
Boiling point (°C)	181	80

Based on the given information, which of the following statements are true?

- A X is a solid at 40 °C.
- B Y is a solid at 90 °C.
- C X is a gas at 100 °C.
- D Y is a liquid at 10 °C.

- A) A and B only
- B) A and D only
- C) C and B only
- D) C and D only

Question 10 of 63

Primary 5 Science (Term 1) 2 pts

Sara lists down some activities which she will like to take in order to conserve water. Which one of the activities below will not allow her to conserve water?

- A) Leaving the tap on when washing the vegetables
- B) Filling water in a tumbler while brushing her teeth
- C) Turning off the shower when applying soap on her body
- D) Washing her father's car using a pail of water instead of using a hose

Question 11 of 63

Primary 5 Science (Term 1) 2 pts

Alex filled two glasses, A and B, with the same amount of water at different temperature.

He then poured all the water from both glasses into a large container. He immediately took the temperature of water in the large container.

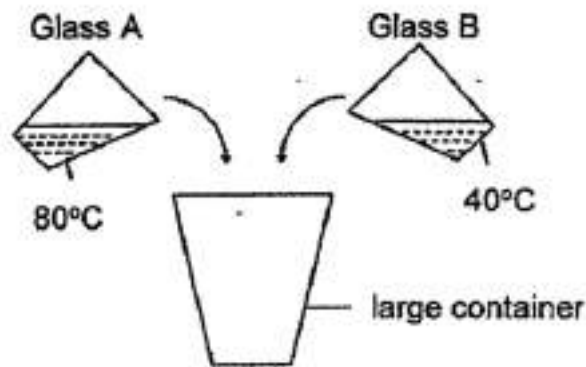

Which one of the following statements about the temperature of the water in the large container is true immediately after the water from the two glasses was first mixed?

- A) The temperature of the water in the large container is the same as the temperature of water in Glass A
- B) The temperature of the water in the large container is the same as the temperature of water in Glass B
- C) The temperature of the water in the large container is higher than the temperature of water in Glass A
- D) The temperature of the water in the large container is higher than the temperature of water in Glass B

The graph below shows the relationship between the number of cells and the age of a healthy human from birth to age 5

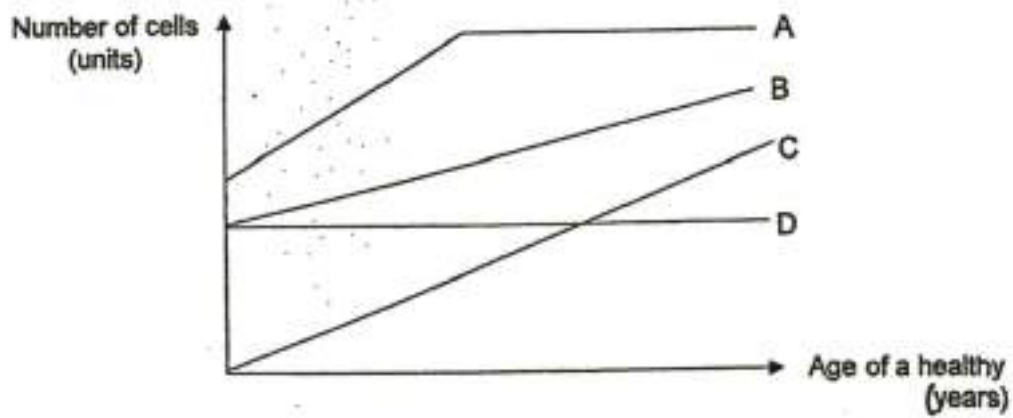

Which one of the lines likely represents the number of cells of the human ?

-
- A) A
- B) B
- C) C
- D) D

Which one of the following statement(s) is/are definitely true about cell X and cell Y?

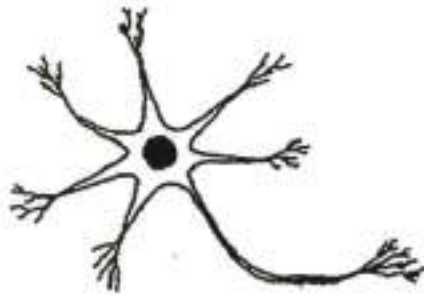

cell X

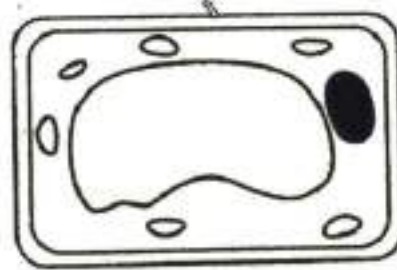

cell Y

- A ✓ Both have only one nucleus.
B ✗ Both can maintain a regular shape.
C ✓ Cell X cannot make food but cell Y can make food.

-
- A) A only
 B) A and C only
 C) B and C only
 D) A, B and C

- The diagram below shows a cross-section of fruit K.

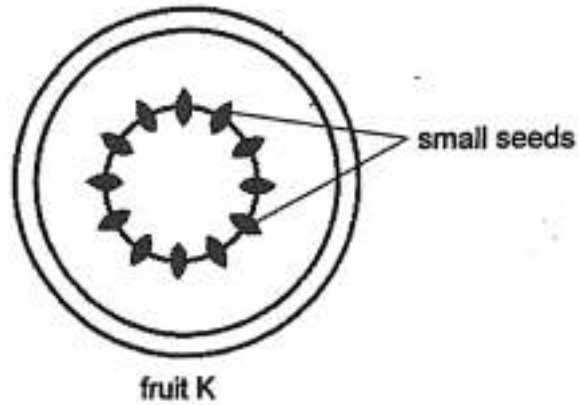

Which of the following statement(s) is/are most likely true about the flower which fruit K has developed from?

- A It has many ovules.
 - B It has many ovaries.
 - C It has many stigmas.
-
- A) A only
 - B) A and B only
 - C) C and B only
 - D) A, B and C

Ben wanted to find out if insects are attracted to the colour of flowers. Which of the following set-ups should he choose to conduct his experiment?

	Set-up X	Set-up Y
(1)	white tulip with no nectar	red rose with no nectar
(2)	yellow rose with nectar	yellow tulip with nectar
(3)	white tulip with no nectar	red tulip with no nectar
(4)	red tulip with nectar	white rose with no nectar

-
- A) 1
- B) 2
- C) 3
- D) 4

The diagram below shows the processes, A, B, C and D, involved in the life cycle of a tomato plant.

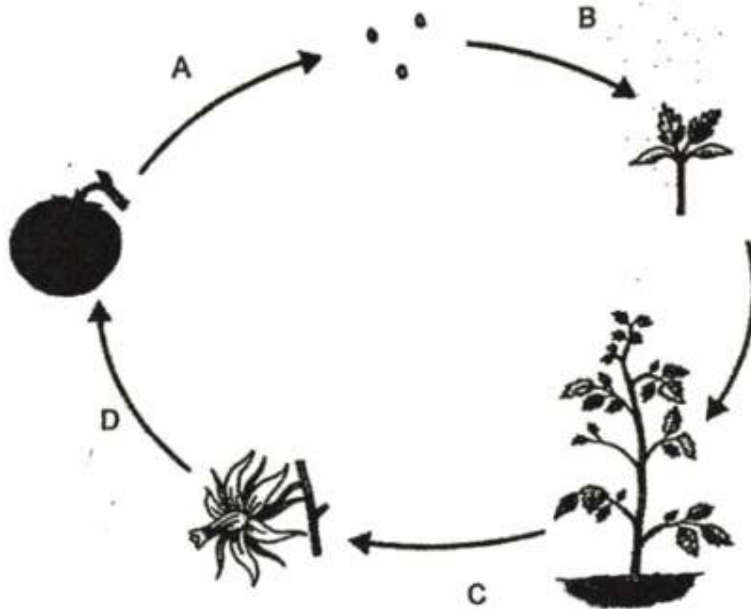

Which one of the following identifies the processes of germination, fertilisation and seed dispersal in the diagram correctly?

	Seed dispersal	Germination	Fertilisation
(1)	A	B	D
(2)	B	C	A
(3)	C	A	D
(4)	D	C	B

- A) 1
- B) 2
- C) 3
- D) 4

The diagram below shows the young of a butterfly and a cockroach.



How are they similar?

- A They do not have wings.
- B They moult in order to grow bigger.
- C They do not resemble their parents.
- D They have the same number of stages in their life cycle.

-
- A) A and B only
 - B) C and D only
 - C) A, B and C only
 - D) A, B, C and D

The diagram below shows the changes of state of water. A, B and C represent different states of water.

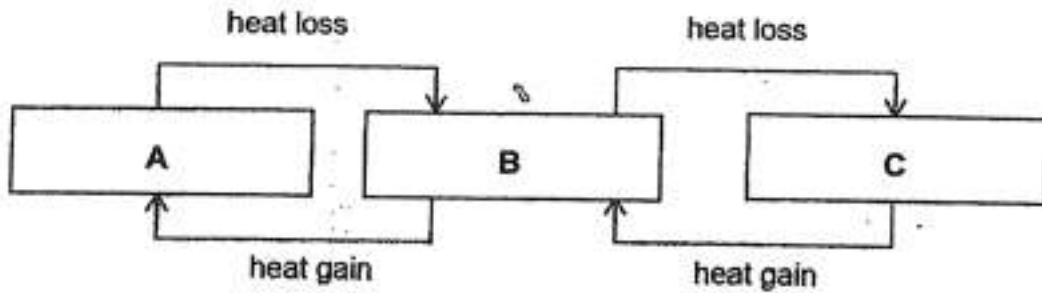

Which one of the following identifies A, B and C correctly?

	A	B	C
(1)	gas	liquid	solid
(2)	gas	solid	liquid
(3)	liquid	gas	solid
(4)	solid	liquid	gas

- A) 1
- B) 2
- C) 3
- D) 4

Three identical cups, X, Y and Z, were filled with 100 ml of water.

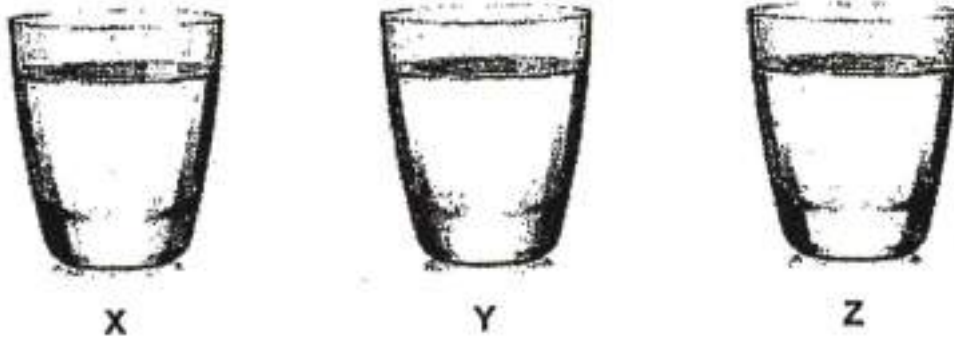

They were left at three places with different conditions, as shown in the table below.

Cup	X	Y	Z
Conditions	sunny, not windy	sunny, windy	cloudy, not windy

Which one of the following graphs best represents the volume of water left in the cups after six hours?

A)

Volume of water (ml)

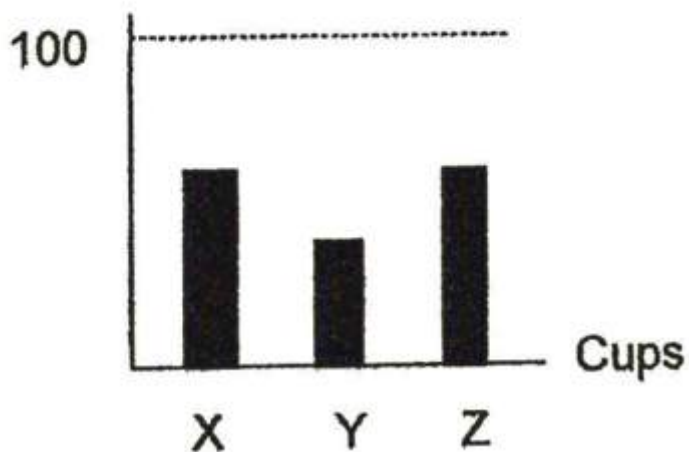

B)

Volume of water (ml)

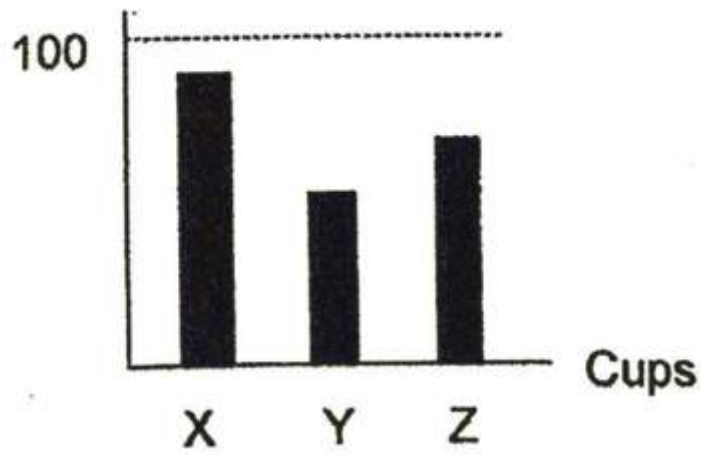

c)

Volume of water (ml)

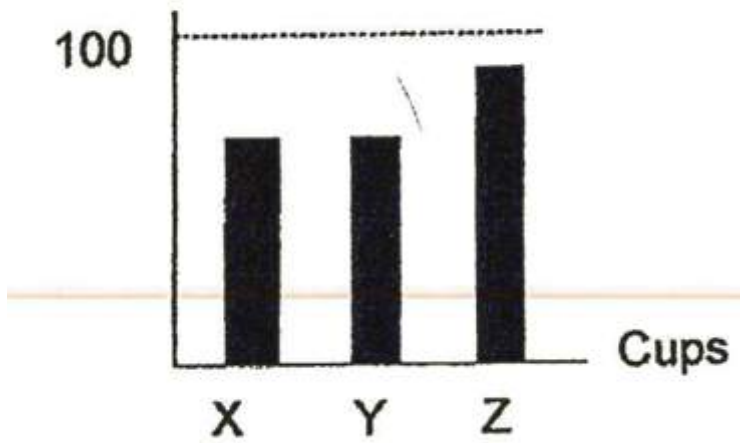

D)

Volume of water (ml)

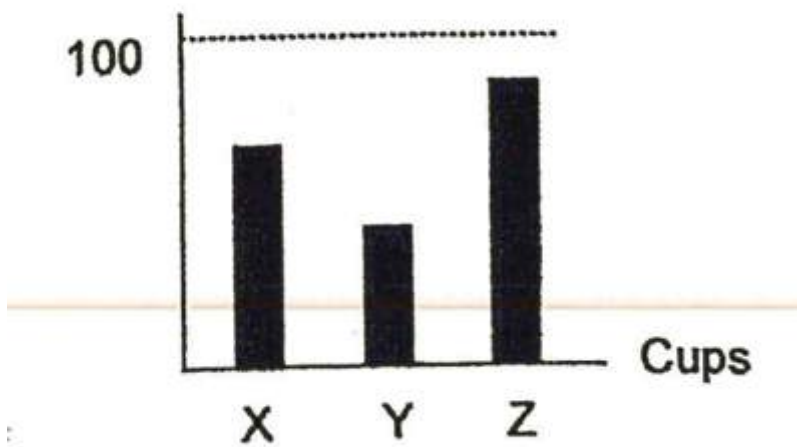

Study the flow chart below carefully.

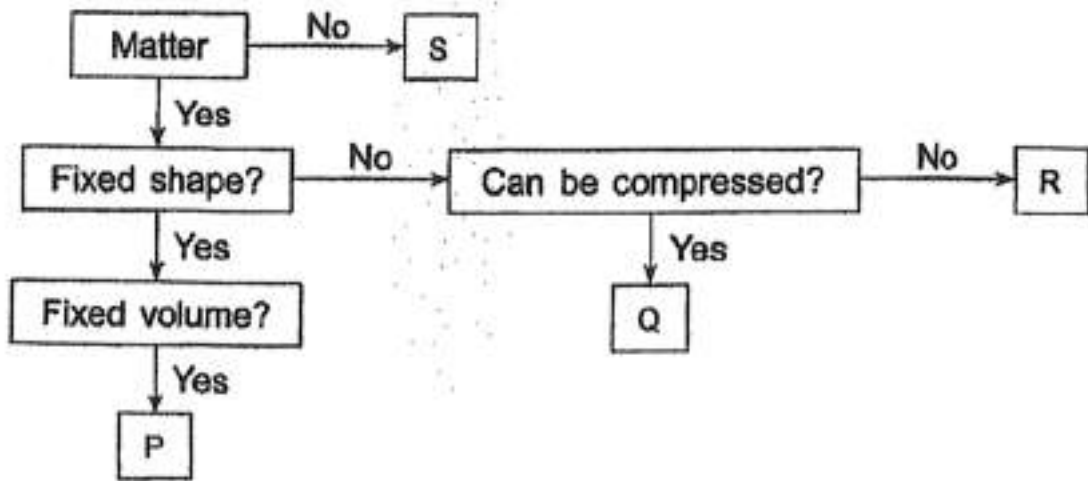

Which of the following best represents P, Q, R and S?

	P	Q	R	S
(1)	milk	air	paper	steam
(2)	paper	air	milk	steam
(3)	ruler	paper	steam	shadow
(4)	paper	steam	milk	shadow

- A) 1
- B) 2
- C) 3
- D) 4

Donald used a pump to fill up a basketball with air. He observed that he was able to pump more air into the basketball even when it was filled.

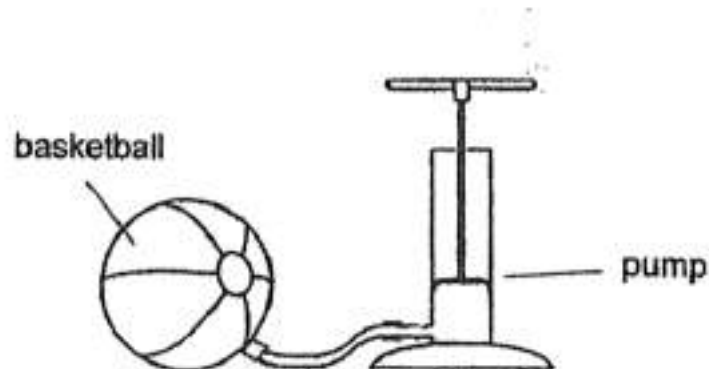

Which one of the following (best) explains his observation?

- A) Air takes up space
- B) Air can be compressed
- C) The basketball has a fixed shape
- D) The basketball has indefinite volume

Fiona placed three objects P, Q and R, on a balance.

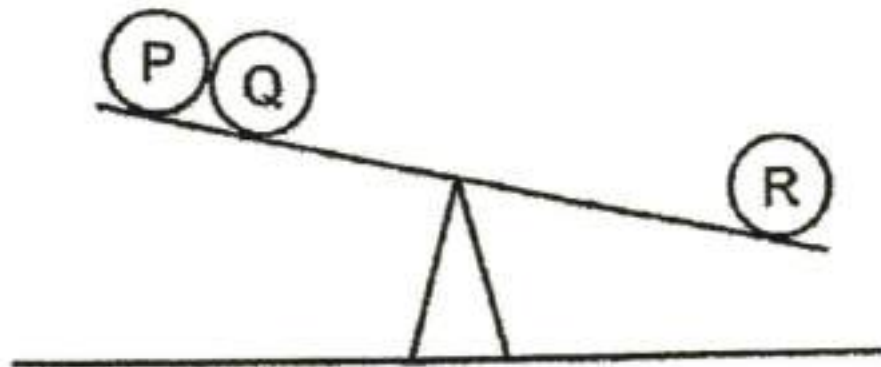

What can she conclude from the observation above?

- A) Object R has the greatest mass
- B) Objects P and Q have the same mass
- C) Object Q has a smaller mass than Object P
- D) Object P has a greater mass than Object R

Which one of the following correctly shows the path of light that makes it possible for the soldier to see the car?

A)

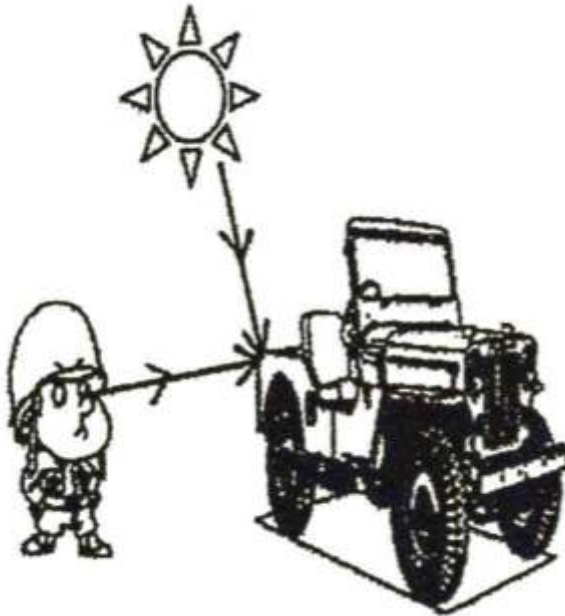

B)

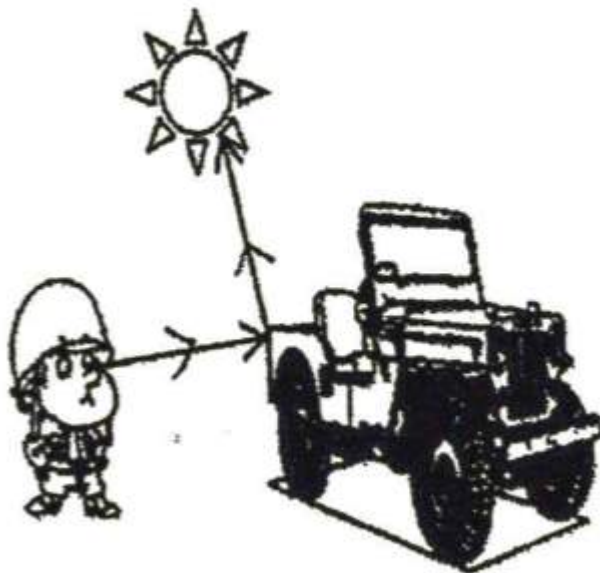

C)

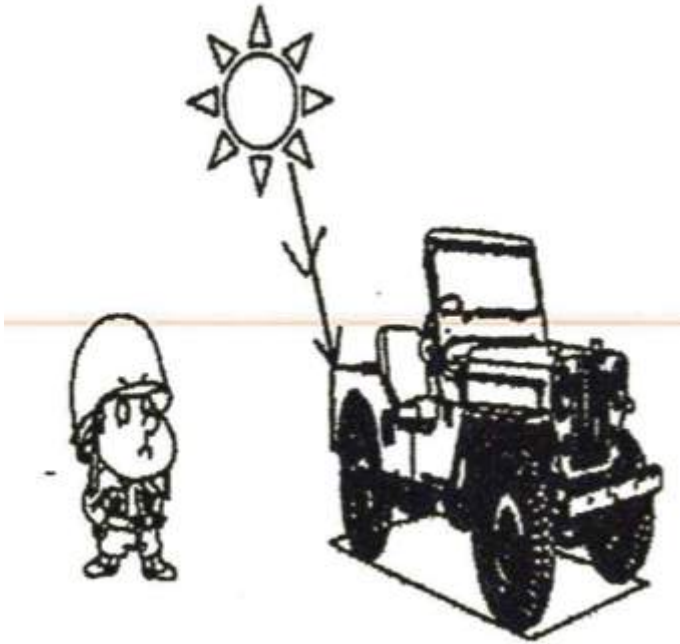

D)

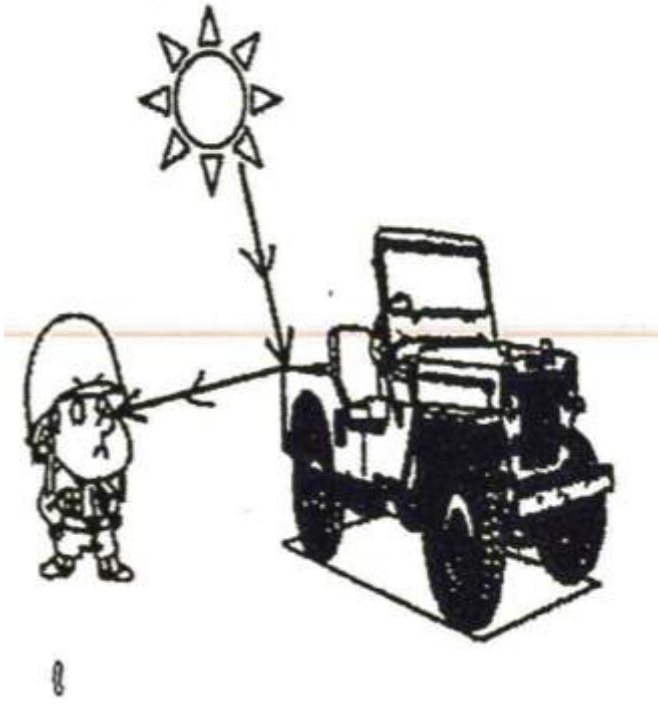

The experiment shown below was carried out in a dark room. Four sheets, K, L, M and N, were arranged in a straight line.

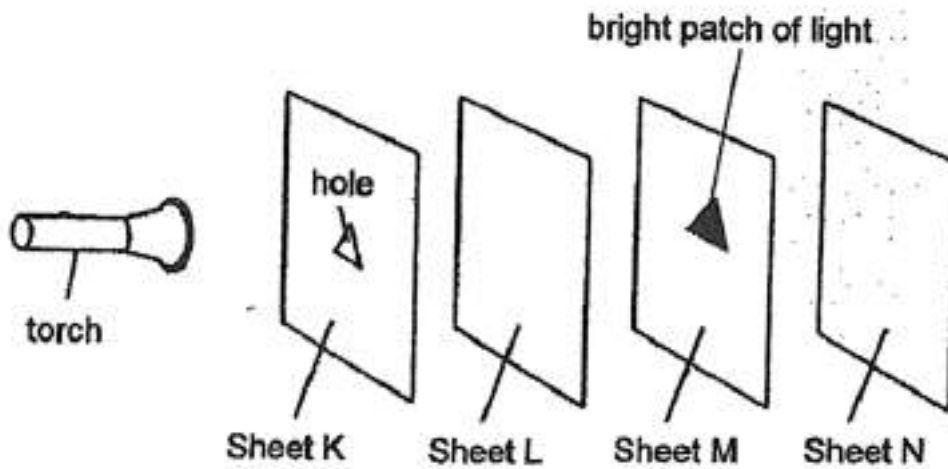

When the torch was switched on, a bright patch of light was seen on sheet M only. Which one of the following correctly describes sheets K, L, M and N?

	Allows light to pass through	Does not allow light to pass through	Not possible to tell
(1)	K	M	L and N
(2)	L	K and M	N
(3)	M and N	L	K
(4)	K	L and M	N

- A) 1
 B) 2
 C) 3
 D) 4

John placed a torch at position A and an object at position D to cast a shadow on the screen as shown in the diagram below.

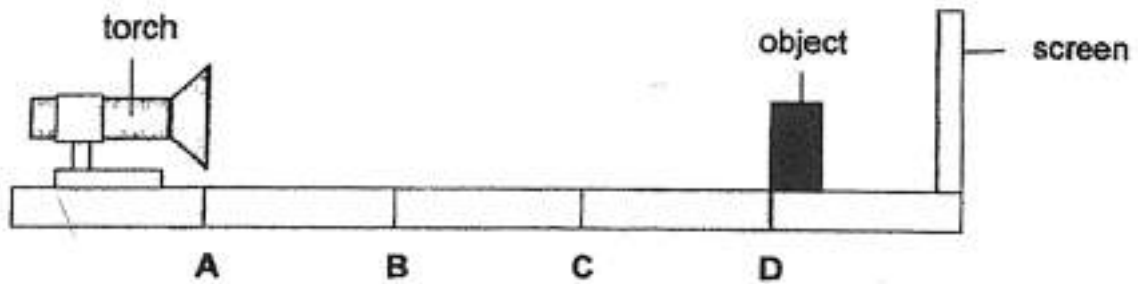

At which positions, A, B, C and D, should the torch and the object be placed such that John can cast the largest shadow on the screen?

	Position of torch	Position of object
(1)	A	C
(2)	B	D
(3)	B	A
(4)	C	D

- A) 1
 B) 2
 C) 3
 D) 4

Daisy poured some hot soup into a ceramic bowl with a metal spoon as shown below.

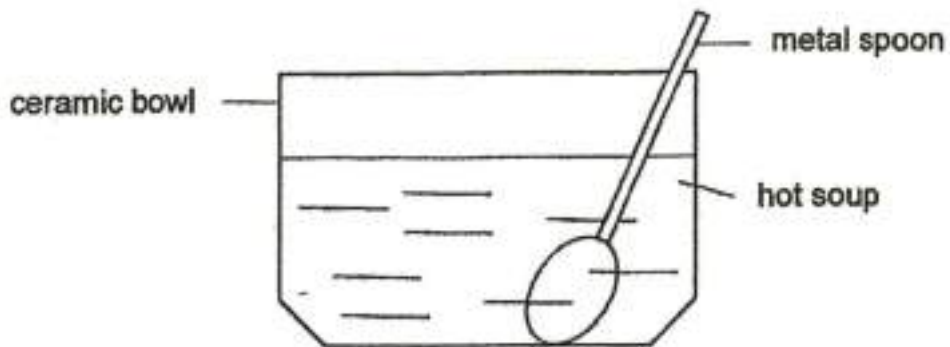

Which one of the following options correctly shows the heat transfer that took place between the hot soup, ceramic bowl and metal spoon after the hot soup was poured into the bowl for five minutes?

	Heat Loss	Heat Gain
(1)	hot soup	ceramic bowl
(2)	ceramic bowl	hot soup
(3)	metal spoon	hot soup
(4)	ceramic bowl	metal spoon

- A) 1
- B) 2
- C) 3
- D) 4

Ginny heated a rod made of material X for 20 minutes.

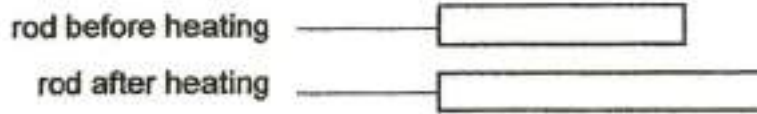

Which of the following changes had taken place in the rod?

	Mass of rod	Volume of rod
(1)	Increased	Increased
(2)	Increased	Remained the same
(3)	Remained the same	Increased
(4)	Remained the same	Remained the same

-
- A) 1
- B) 2
- C) 3
- D) 4

David heated objects X and Y. He recorded the change in temperature of both objects in the graph below.

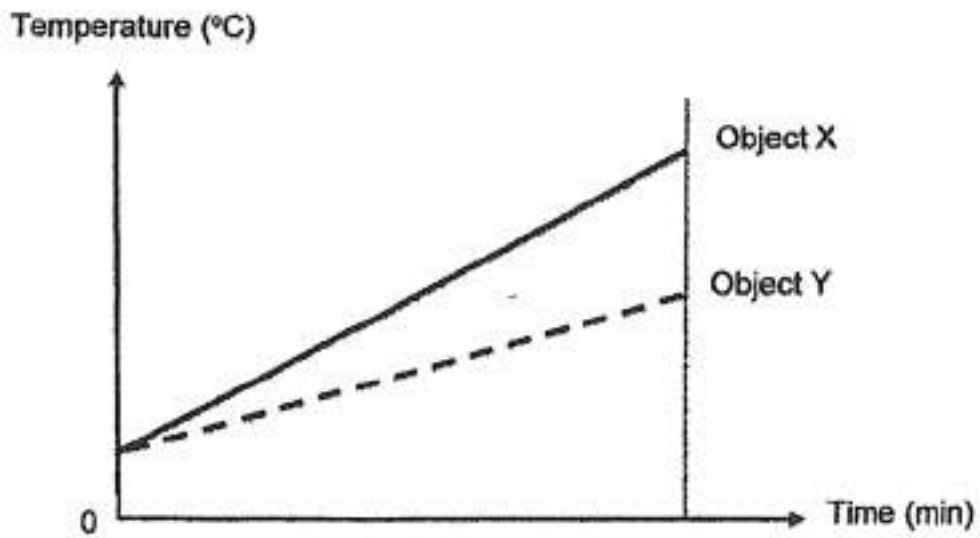

Which one of the following statements best explains the results shown in the graph above?

- A) Object Y is not a conductor of heat
- B) Object Y gains heat faster than Object X
- C) Object X is a better conductor of heat than Object Y
- D) Object X takes a longer time to lose the same amount of heat than Object Y

For each question, write your answers in the space provided.
(44 Marks)

Mary used an apparatus to observe some cells taken from a part of a plant as shown in the diagram below.

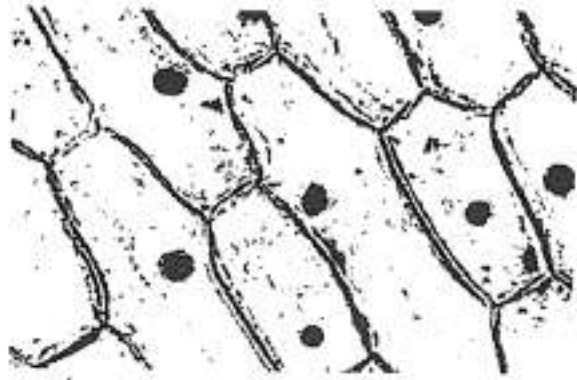

(a) Name the apparatus that is used to observe these cells.

Label and name the part of the cell that contains genetic information.

Are these cells taken from the green leaves of the plant? Give a reason to support your answer.

The diagram below shows Flower X which is found in a garden.

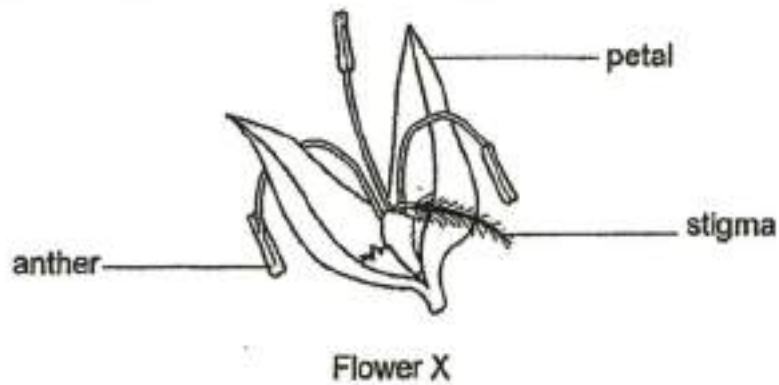

(a) Identify the parts of the flower that carry out the functions stated in the table below. [1]

(i) _____	(ii) _____
Contains pollen grains	Receives pollen grains during pollination

Based on the diagram above, what is the likely method of pollination of Flower X?

Explain how the position of the stigma helps the flower to be pollinated.

The flow chart below shows the characteristics of the life cycle of animals.

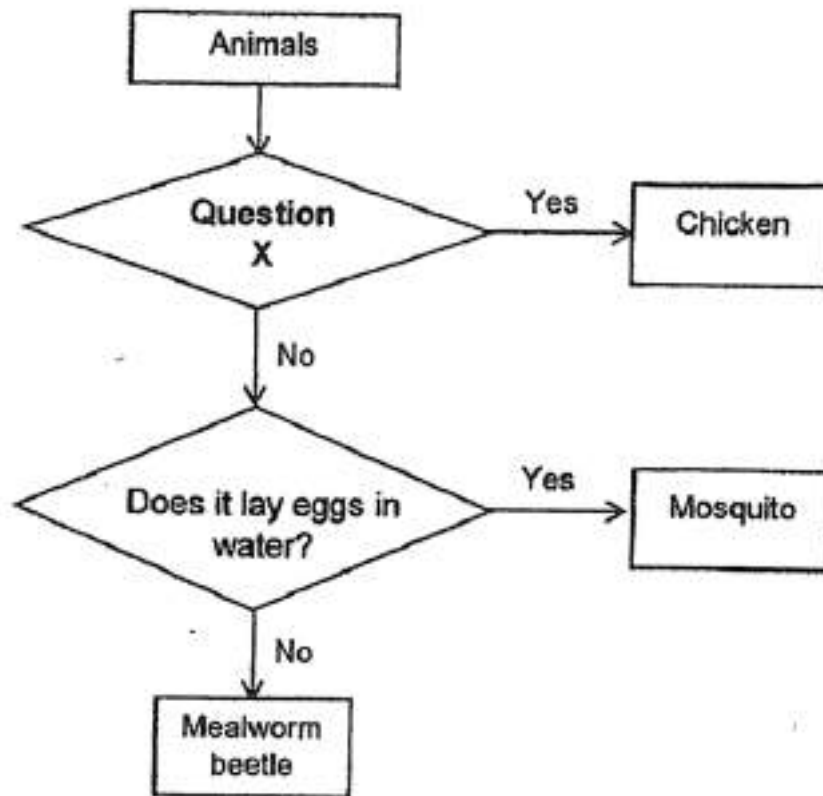

(a) Write a suitable question for X in the flow chart above.

Draw a diagram of the life cycle of the mosquito and label the stages

Name another insect that has the same number of stages in its life cycle as the mealworm beetle and the mosquito.

Study the diagram below.

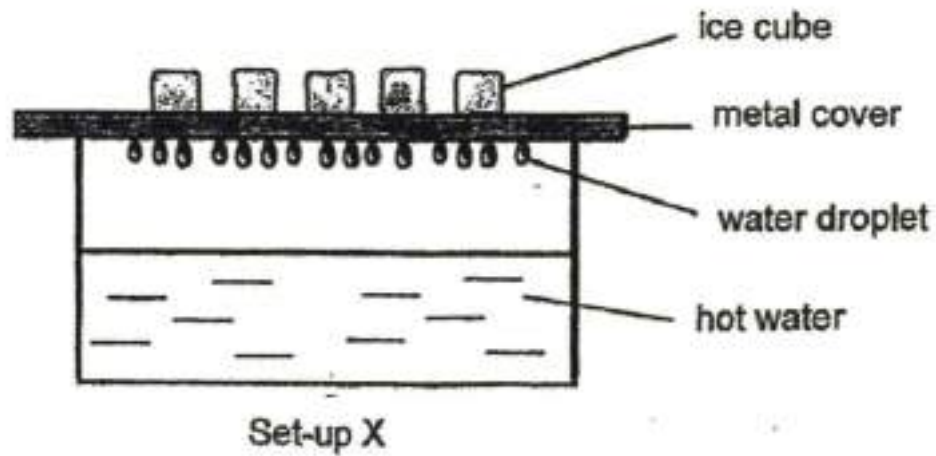

- (a) Explain how the water droplets are formed in the above set-up.
-

Lesser water droplets was formed in the set-up below.

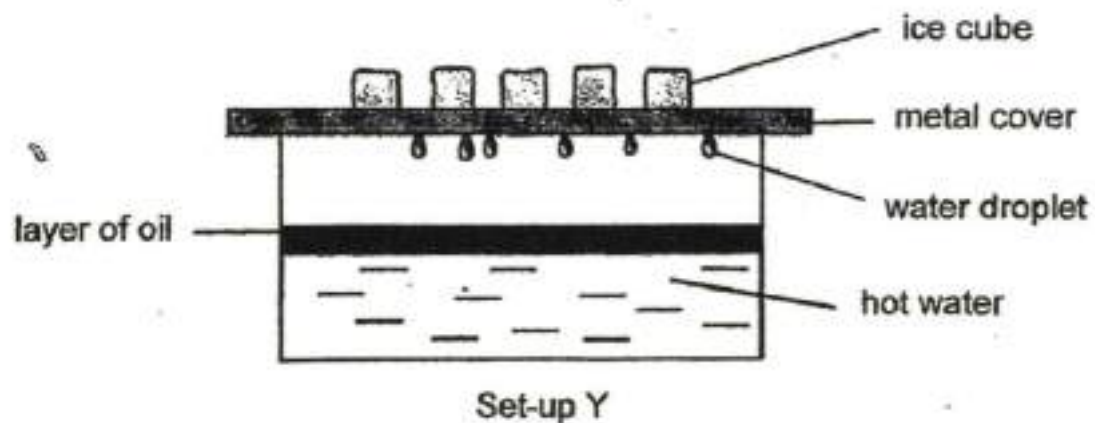

- (b) Explain why lesser water droplets were formed in the set-up.
-

Lisa set up an experiment as shown below.

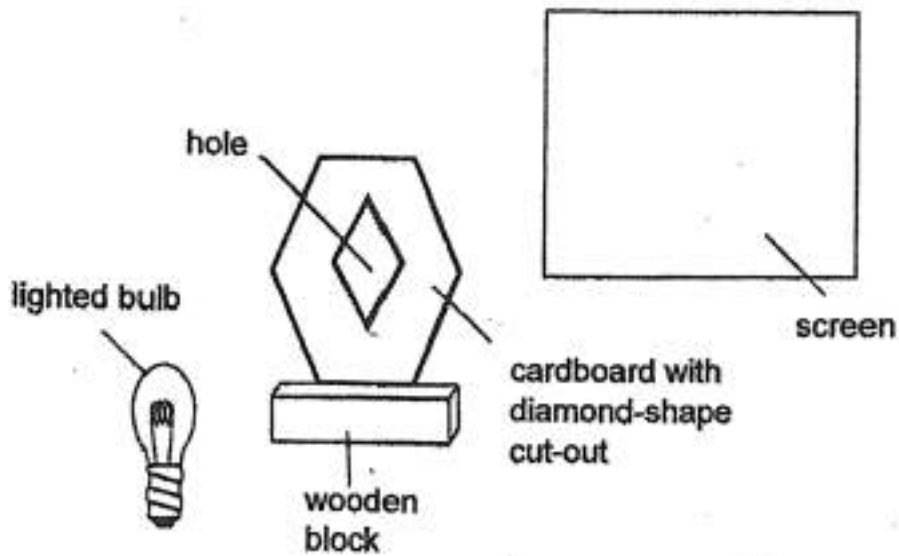

- (a) A shadow was cast on the white screen when a lighted bulb was placed in front of the cardboard. Shade the diagram below to show how the shadow would look like. [1]

Question 41 of 63

Primary 5 Science (Term 1) 0 pts

Lisa placed a glass sheet in front of the cardboard. Will the same shadow in (a) be formed on the screen? Explain your answer.

Question 42 of 63

Primary 5 Science (Term 1) 0 pts

What would happen to the size of the shadow if Lisa moved the cardboard nearer to the light bulb without changing other parts to the set-up?

Question 43 of 63

Primary 5 Science (Term 1) 0 pts

Explain your answer in part (c)

Question 44 of 63

Primary 5 Science (Term 1) 0 pts

The diagrams below show Cell S and Cell T.

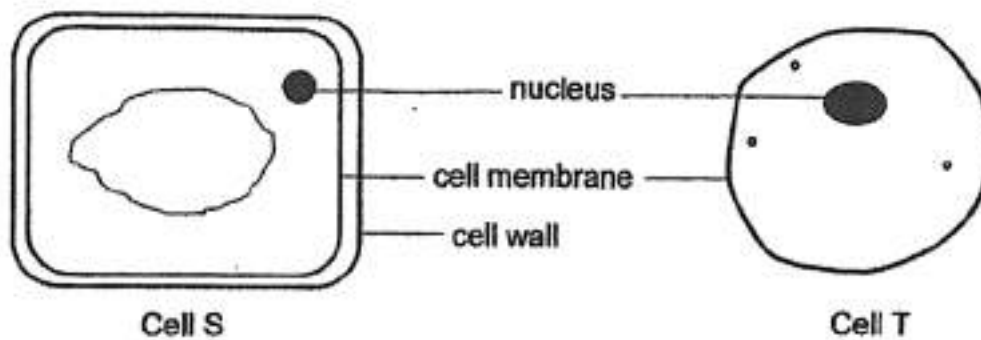

Amanda conducts an experiment to find out what happens when both of the cells absorb too much water.

Both cells are placed in water for 5 minutes so that they can absorb as much water as possible. After 5 minutes, Amanda recorded her observations in the table below.

Cell S placed in water	Cell T placed in water
The cell stiffens but maintains its regular shape	The cell burst and becomes out of shape

(a) Explain the difference in the observations of Cell S and Cell T after 5 minutes.

Question 45 of 63

Primary 5 Science (Term 1) 1 pt

Besides the parts labelled in the diagrams above, name another part that is found in both cells.

Devi set up an experiment as shown below to find out if light is needed for seed germination. Her teacher told her that her experiment is not a fair test.

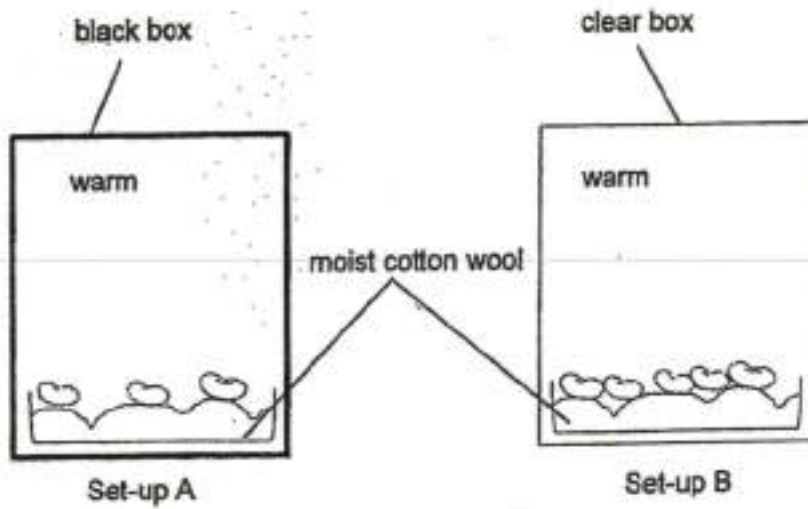

- (a) What change should Devi make to set-up B so as to ensure a fair test? [1]

In which set-up(s) will the seeds germinate? Explain your answer

Devi then measured the mass of the seed leaves as the seeds germinate. The table below shows how the mass of the seed leaves changed over time.

Number of days	1	2	3	4	5	6
Mass of seed leaves (gram)	8	7	5	2	2	2

- (c) What is the relationship between the number of days and the mass of seed leaves? [1]
-

How many days do the seedlings take to develop its first pair of green leaves? Explain your answer

While walking to school, Tim found a fruit as shown below.



- (a) Label and name the structure of the fruit above that enables the seeds of the fruit to be dispersed. (1)

Tim brought it to school and drew a diagram below to show how the fruit would be dispersed.

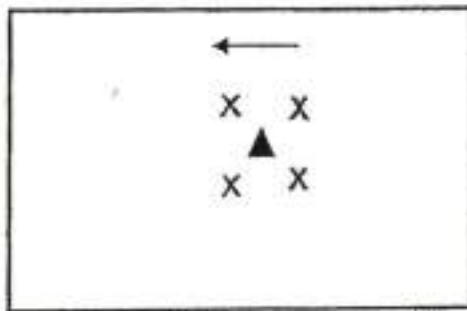

Key	
←	Wind direction
▲	Parent plant
X	Seedlings

- (b) His teacher told him that his diagram was drawn wrongly. Using the symbols given in the key, draw 4 seedlings to show how the seeds will be dispersed in the box below. (1)

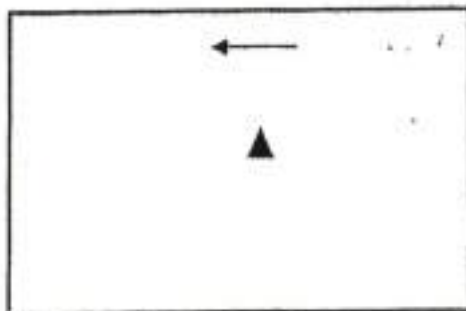

What is the advantage of dispersing the seeds of the fruit?

Jack filled three containers, A, B and C, with an equal volume of water and placed them under the Sun. He measured the volume of water left in each of the containers after 30 minutes.

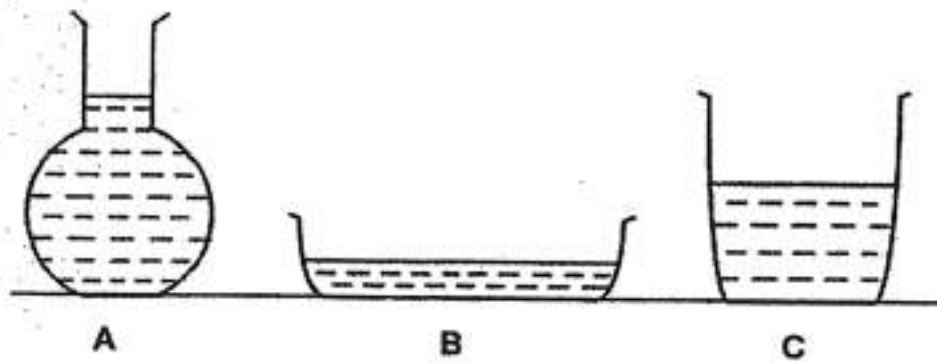

- (a) What is the independent variable (variable changed) in this experiment?
-

The graph below shows the results of his experiment.

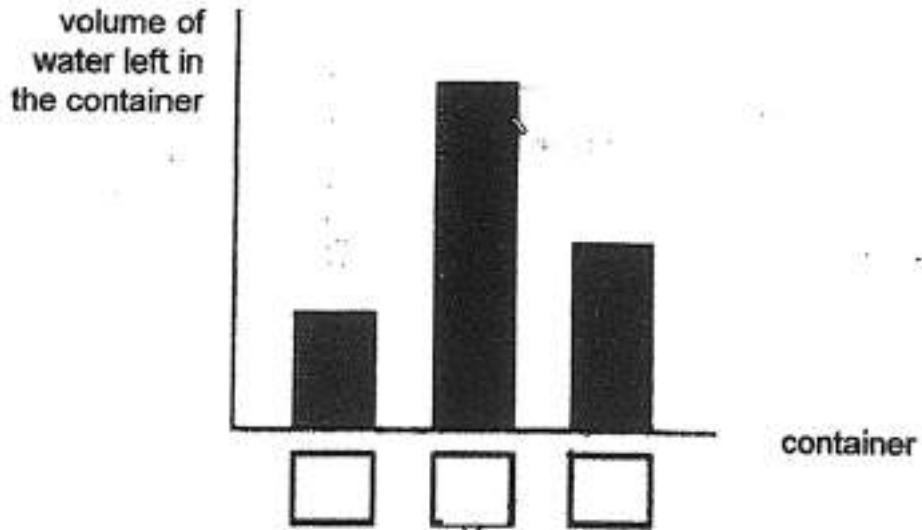

- (b) Fill in the boxes in the graph above with the letters A, B and C to show the correct containers. [1]
-

>

After a heavy rain, Jack and his friends from the basketball team were spreading out the puddles of water on the basketball court. Due to safety reason, the school does not allow students to play at the basketball court if the ground is wet.



- (c) Explain how spreading out the puddles of water will allow Jack and his friends to shorten the waiting time to play at the basketball court. [2]
-

Observe the diagrams below.



(a) Identify the states of the matter for salt and milk.

(i) Salt _____

a(ii) Milk: _____

State one similar property between the two matters shown above.

Tasha then filled a syringe with rice grains and tried to push the plunger in as shown in the diagram below.

She managed to push the plunger in slightly for a few millimetres (mm).

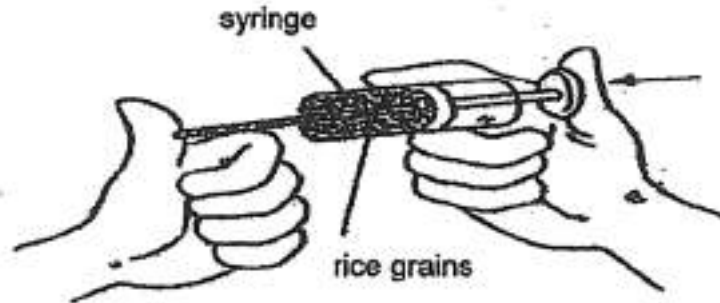

(c) Explain why Tasha was able to push the plunger in slightly.

[2]

You are given a lighted candle, a metal ball and a metal ring as shown below. The metal ball is able to pass through the ring before being heated.



(a) Using the apparatus given, describe the steps you would take to show that metal expands when heated. [2]

In another experiment, Mary heated a bimetallic strip for 5 minutes. The strip is made up of two different metals, A and B, which expand at different rates.



- (b) Why did the bimetallic strip bend after being heated? [1]

Ice cream pudding is prepared by placing ice cream covered in beaten egg whites on top of a sponge cake as shown in the diagram below.

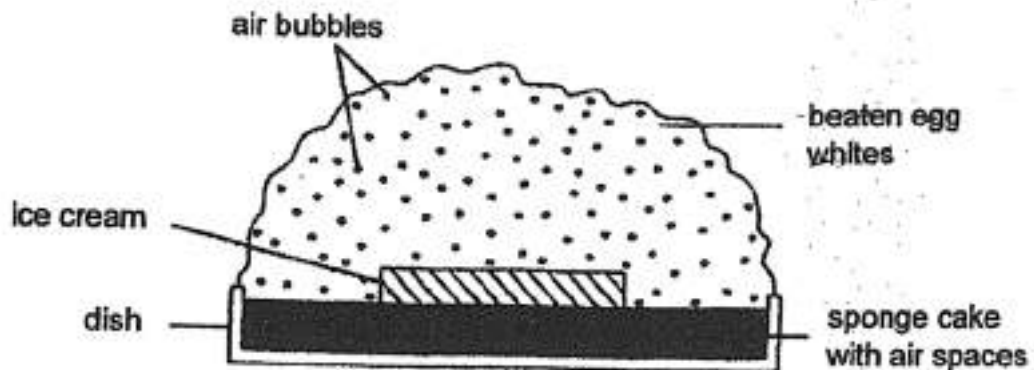

The pudding is then baked in a hot oven for a few minutes. The ice cream will not melt in the process of baking.

- (a) Based on the diagram above, explain why the ice cream did not melt? [2]

Question 63 of 63

Primary 5 Science (Term 1)

0 pts

Explain why the ice cream melted quickly when the pudding was cut into smaller sections when served.
